

MAXIMA ML

4030W

TECHNICAL DATA:

CAPACITY PER COLUMN:	7500 Kg
LIFTING HEIGHT:	1700 mm
LENGTH FORKS:	320 mm
WIDTH FORKS:	380-620 mm
HEIGHT COLUMNS:	2300 mm
OVERALL LENGTH:	1275 mm
OVERALL WIDTH:	1100 mm
OVERALL HEIGHT:	3655 mm
LIFTING TIME:	≤ 90 sec
POWER SUPPLY:	24V DC motor with two batteries per column
MOC SILNIKA:	2.2 Kw
WAGA KOLUMNY:	580 kg
BATTERY CYCLES:	20 cycles up / down (full load)
CHARGING:	The possibility of recharging during work
QUANTITY COLUMN:	Up to 16 columns can be connected
TIRE DIAMETER:	from 19" to 44"

MAXIMA ML 4030W (from 4 to 16 columns) Lift is designed for the assembly, repair, maintenance, oil-change and other services of various commercial vehicles.



MAXIMA ML4030W electrohydraulic mobile column lift, electronic steering and sync single, double, four or all columns operation, LCD display with operation parameters, hydraulic-mechanical lock, thermal motor control, adjustable forks from 16" to 23", CE certificate.

Adopts unique hydraulic vertical lifting system and advanced high-precision balancing control device, to ensure perfect synchronization of the hydraulic cylinders and ultimately ensure the smooth up and down of lifts. MAXIMA ML Lift is designed for the assembly, repair, maintenance, oil-change and other services of various commercial vehicles, such as urban public traffic vehicles, passenger coaches and heavy duty trucks etc.

FEATURES:

Unique Synchronization System:

It ensures smooth up and down of the lift.

Human Engineering:

One lifting column (Master column) function as the carrying agency. The lift also includes an independent electrical control system, a hydraulic power unit as well as an emergency descent device in case of power failure.

Unique structure:

Independent column greatly increase the mobility and versatility in width and spacing of the vehicle.

Furthermore, the „L”-type spares more repair space under the platform, thus ensuring free passage of servicing equipments underneath.

High Cost-effectiveness:

Electronic and hydraulic control systems cooperate with the control box, which significantly simplifies the construction of the lift, which facilitates daily operation. The crane itself is easy to set up as well as folding, it can be easily moved because it has a mobile structure.

Safety Assurance:

The lift has double security under the load status, i.e. Hydraulic support and mechanical lock; It is also designed with limit switch, so it can stop in a short time when the final position is reached. In case of any unexpected power failure, the lift can be lowered. In addition, the lift is also equipped with an overload protection.

GROUND REQUIERMENT:

Foundation and surface should withstand pressure min. 15 Mpa

Surface incline: no more than 1:1200

Floor inequality in the working area: max. 10 mm

Ability to work indoors and outdoors

Operation temperature range: 5 °C – 40 °C

Permissible humidity: 50%/40 °C – 90%/20 °C



POSSIBILITY OF CONFIGURATION IN
VERSION 4 OR 16 COLUMNS



CONTROL PANEL LCD



DIMENSIONS OF COLUMN

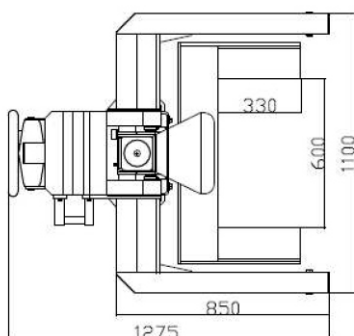
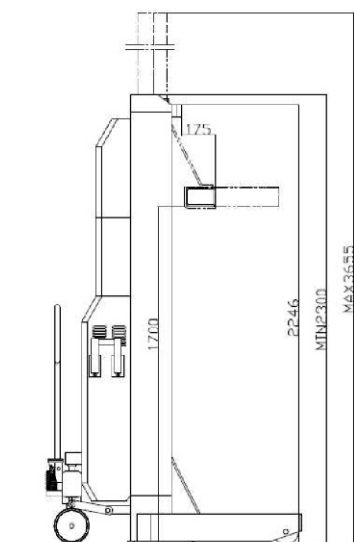

OPTIONAL EQUIPMENT
ASSEMBLY SUPPORT 7500 kg

