

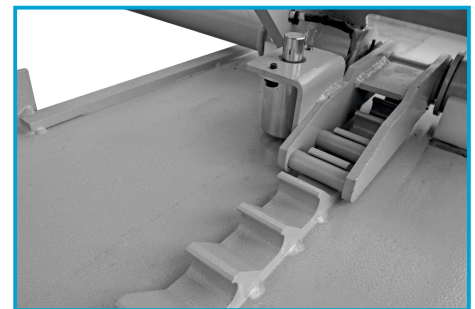

PN3500DXL

CAPACITY:	3500 kg
POWER SUPPLY:	230V/50Hz
MOTOR POWER:	2,2 kW
LIFTING HEIGHT:	110-1200 mm
PLATFORM LENGHT:	1660-2250 mm
NOISE LEVEL:	<70 dB
WEIGHT:	500 kg

Electrohydraulic scissor lift with moving possibility • stable construction
 • mechanical height lock electrically released • mechanically synchronized adjustable platforms • rubber pads and moving set in standard equipment
 • safety appliances in order to EN1493:2010 • oil HL22 10 liters.

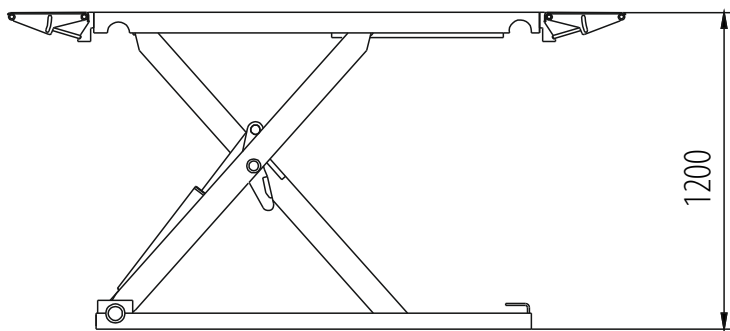

ELECTRICALLY CONTROLLED HEIGHT LOCK



CYLINDERS WITH A LOAD CAPACITY OF 3500 KG



INITIAL LIFT PHASE SUPPORT SYSTEM

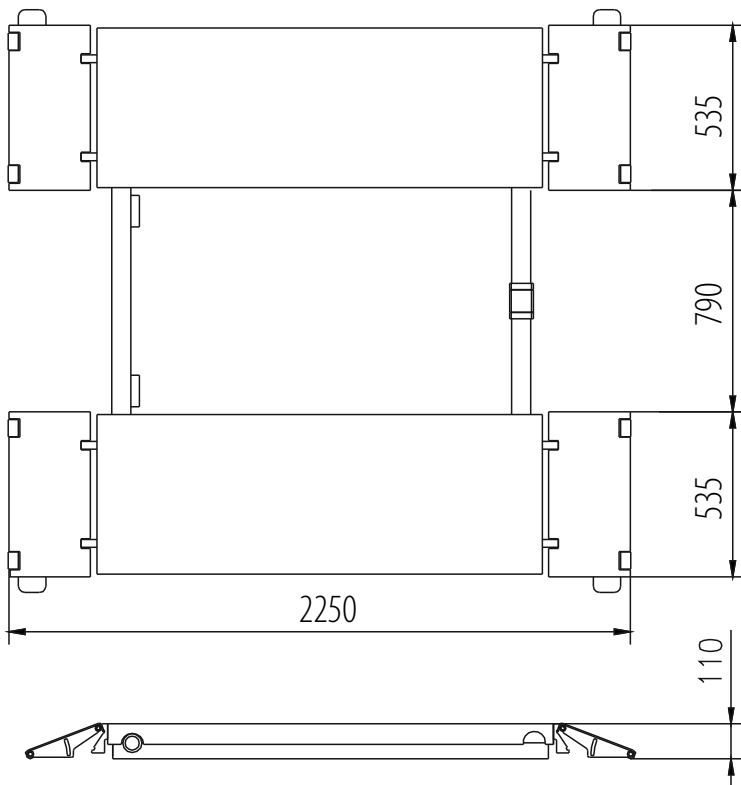



GENTLE ACCESS TO THE LIFT

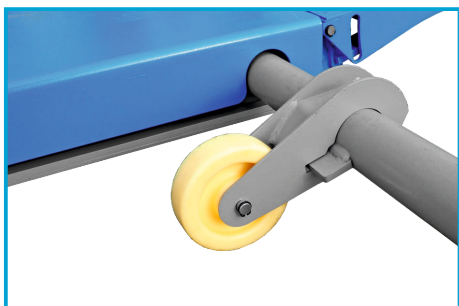

WHEELS THAT MAKE IT EASY TO MOVE
THE LIFT



ADJUSTABLE PLATFORM LENGTH
FROM 1660 mm TO 2250 mm



LIFT MOVING KIT
RUBBER SPACERS 4 PCS.

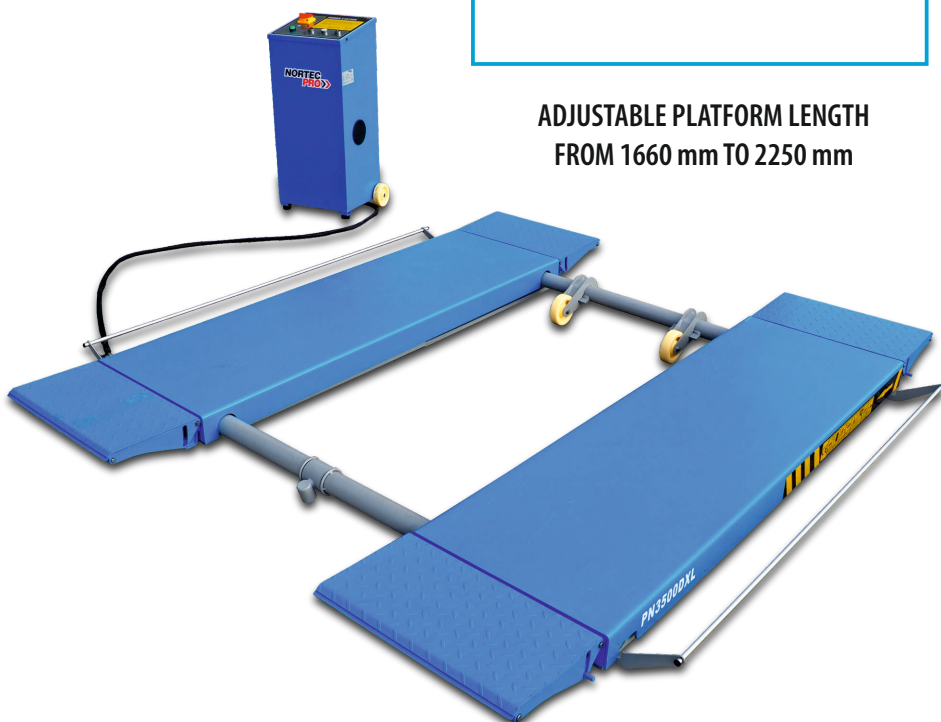

COMPACT DIMENSIONS AFTER FOLDING